

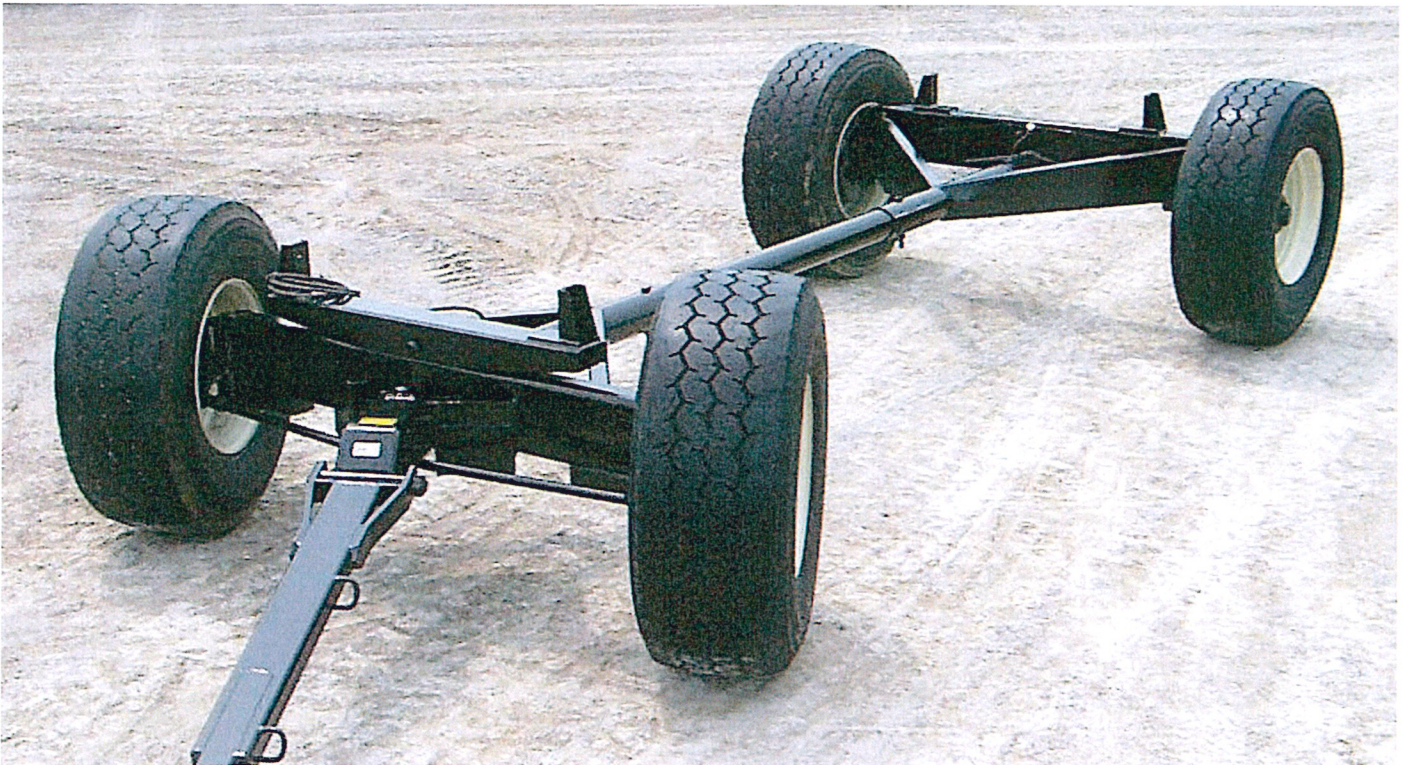

**OPERATOR'S MANUAL
SET-UP INSTRUCTIONS
&
PARTS LIST**

WAGON PARTS



MARKET FARM EQUIPMENT LIMITED, R.R.#1 DASHWOOD, ONTARIO, CANADA

TEL# 519-238-2301 FAX# 519-238-6044 E-MAIL: mfeltd@execulink.com

www.marketfarmequipment.com

"SERVING THE FARM INDUSTRY SINCE 1962"

10/11 ton WAGON

(Front)

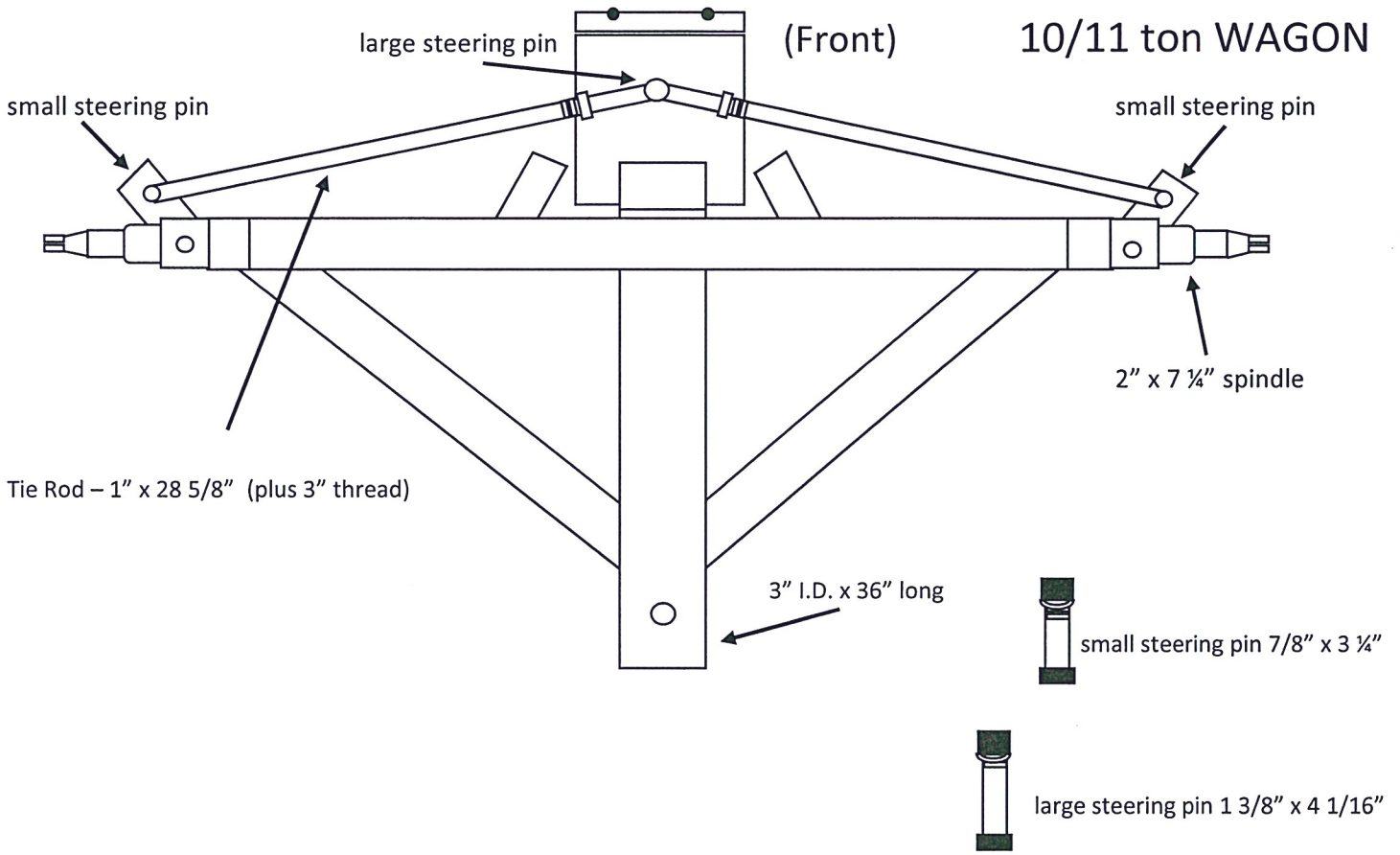

(Rear)

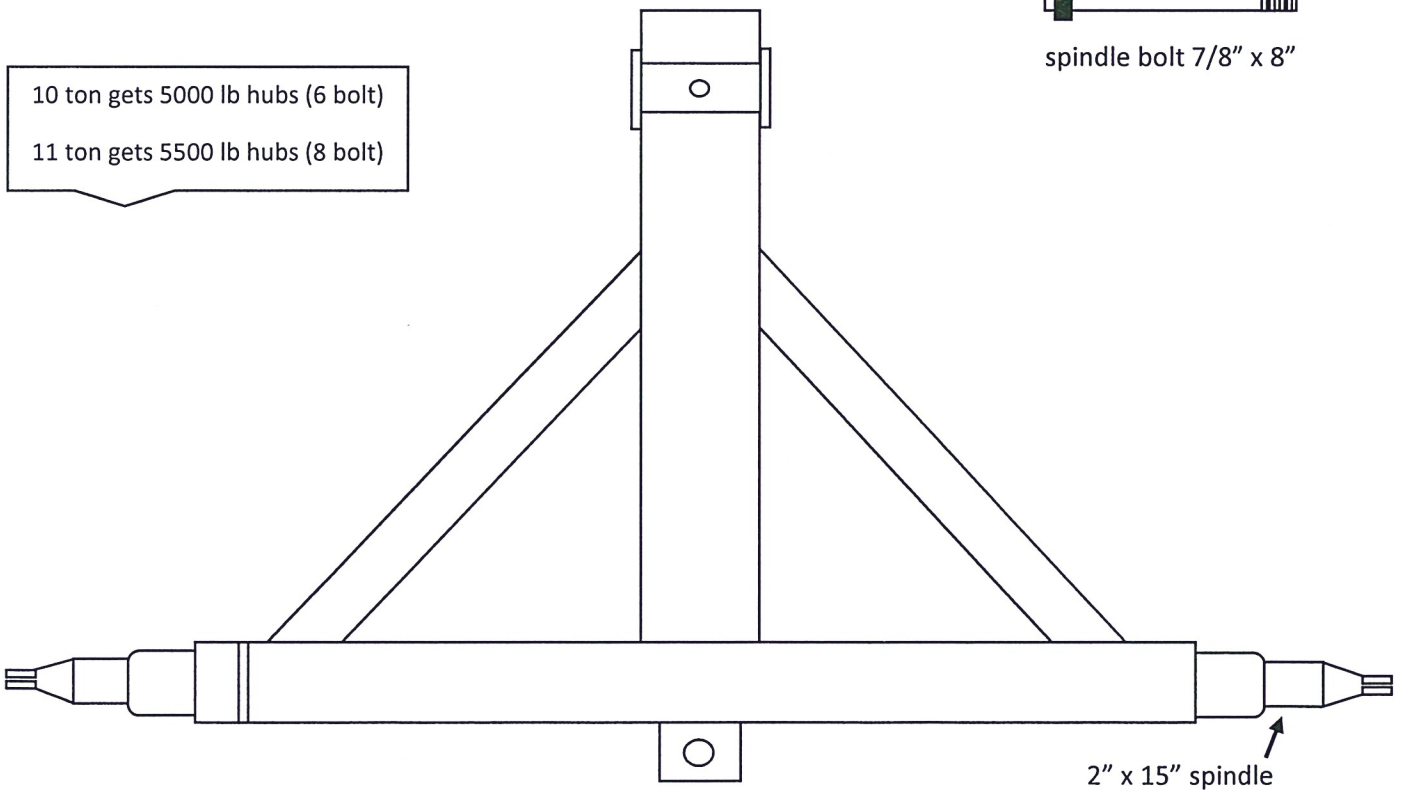

12 Ton (R.B.) Wagon

FRONT

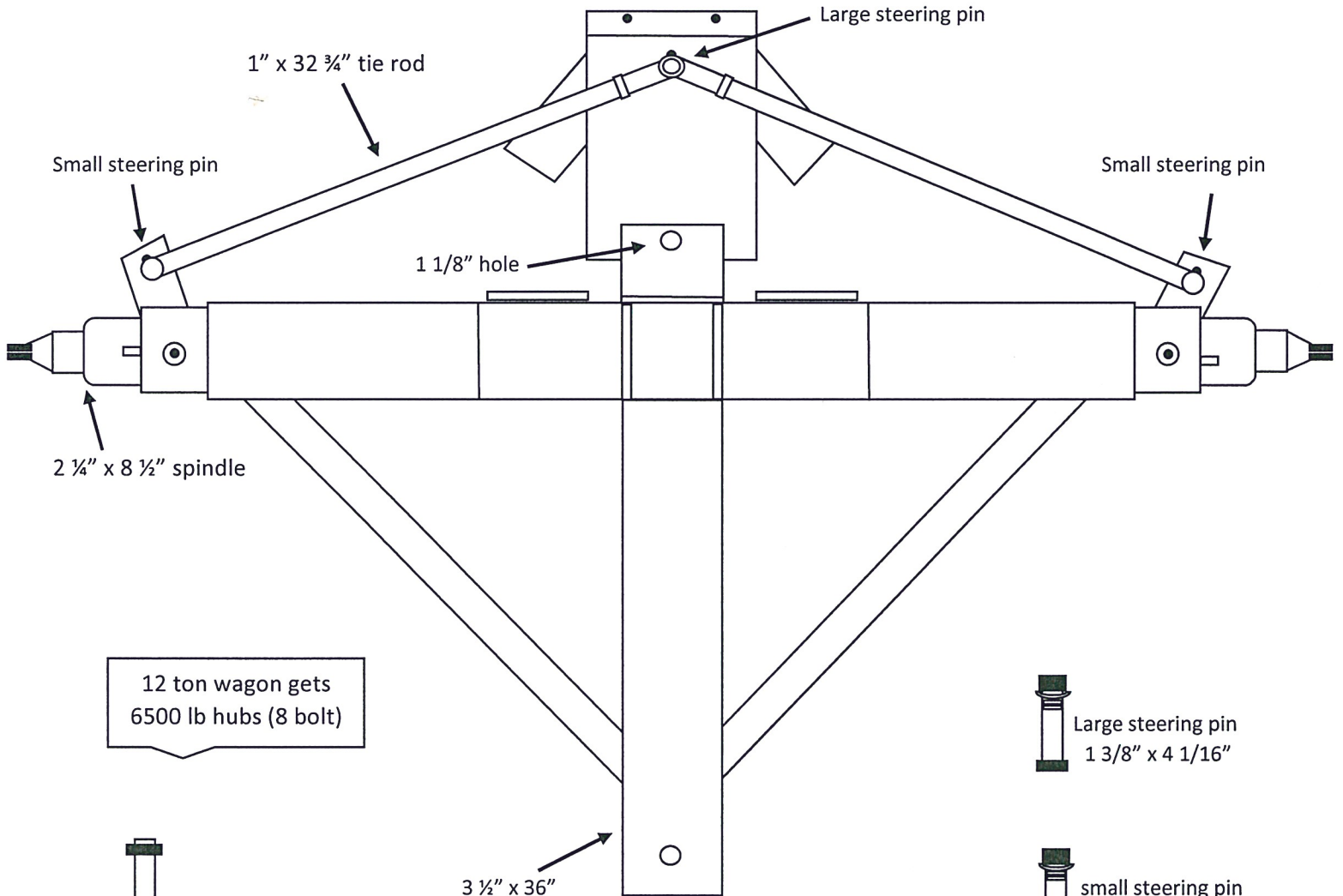

REAR

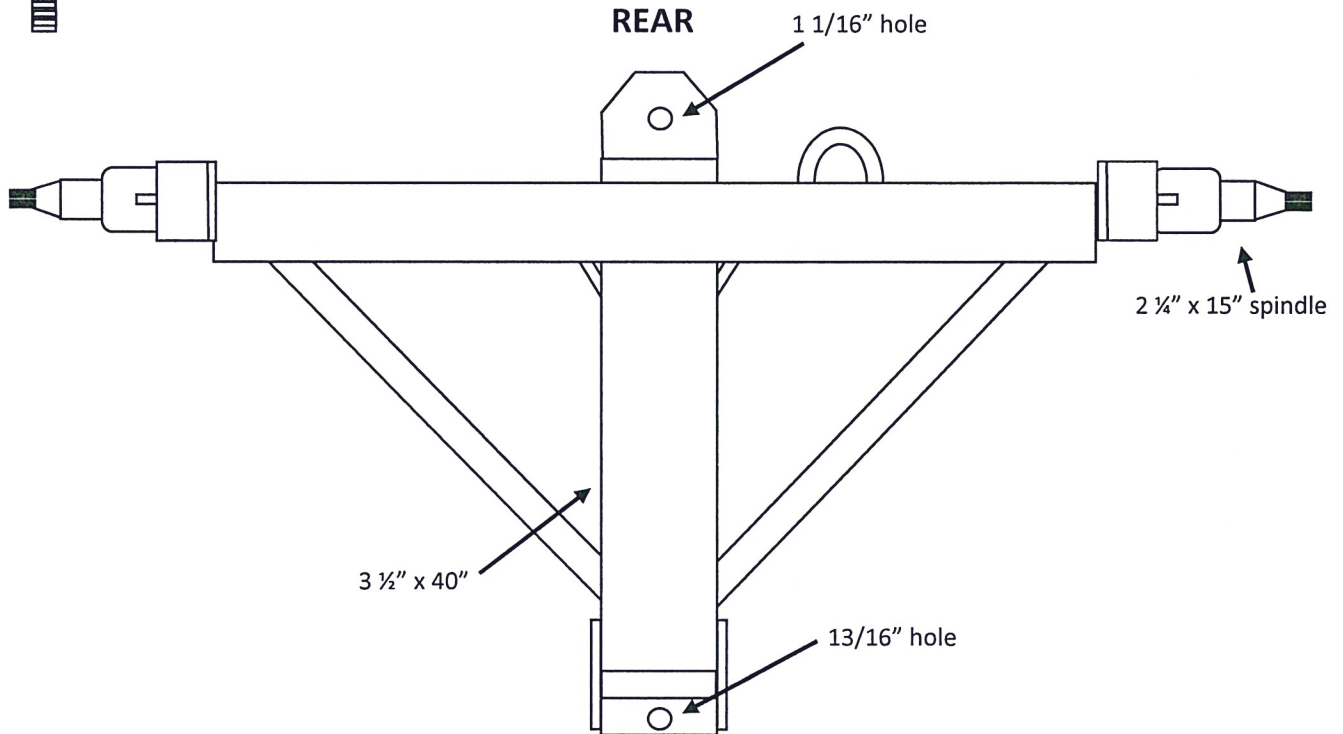

10/12 TON tongues



Tongue bolt 1 1/8" x 9 7/16"

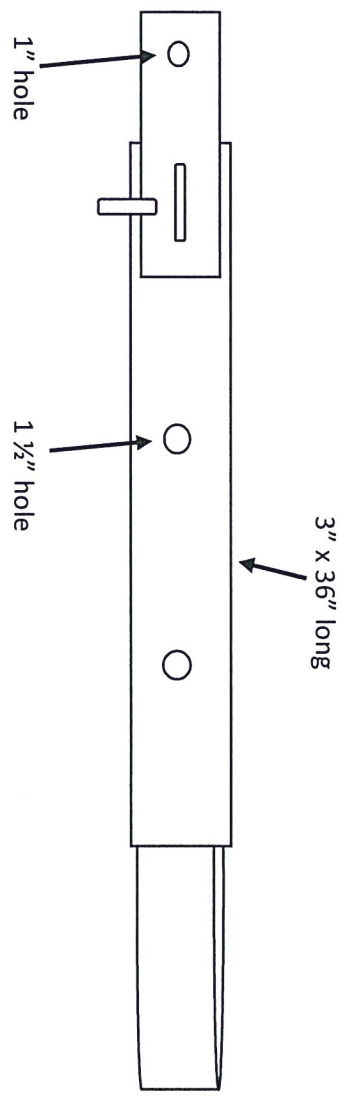
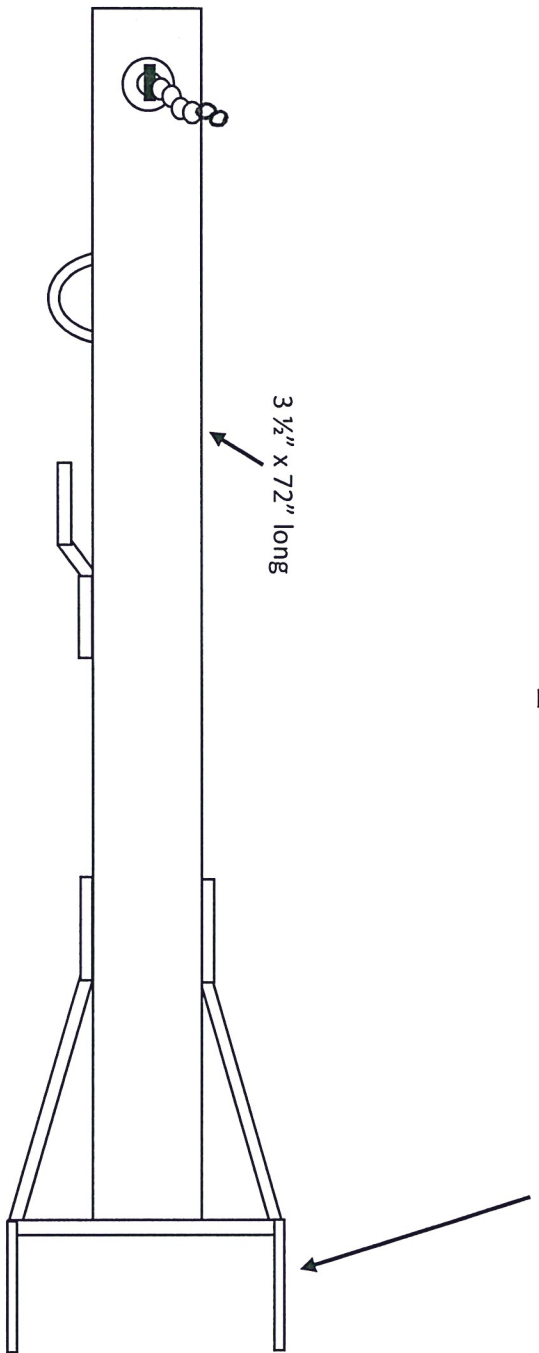

10/12 TON Short Tongue (Hitch)

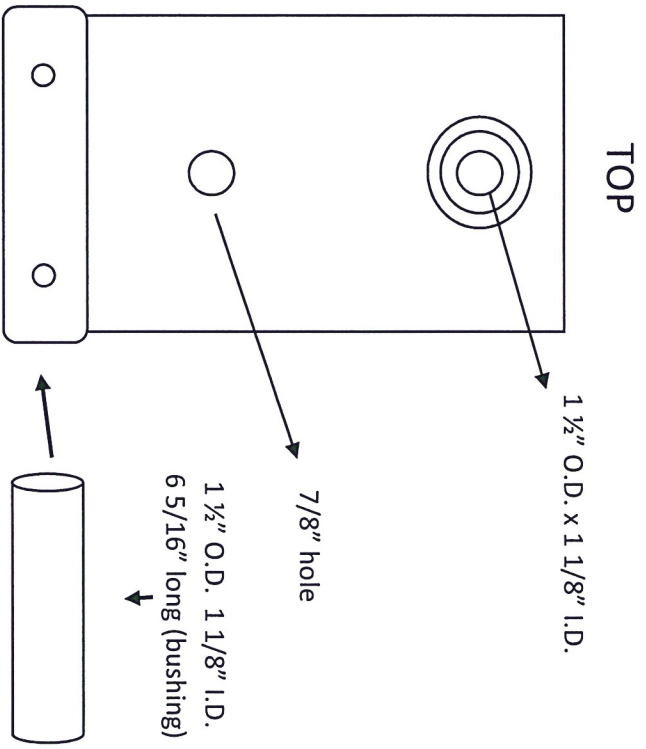

BOTTOM

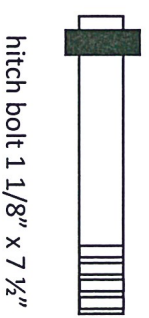
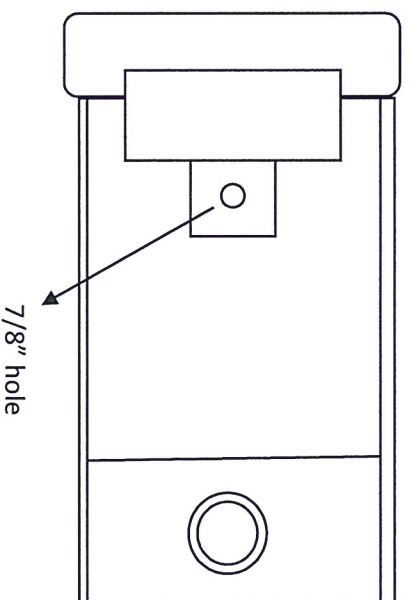

14 TON TONGUE (Inner and Outer)

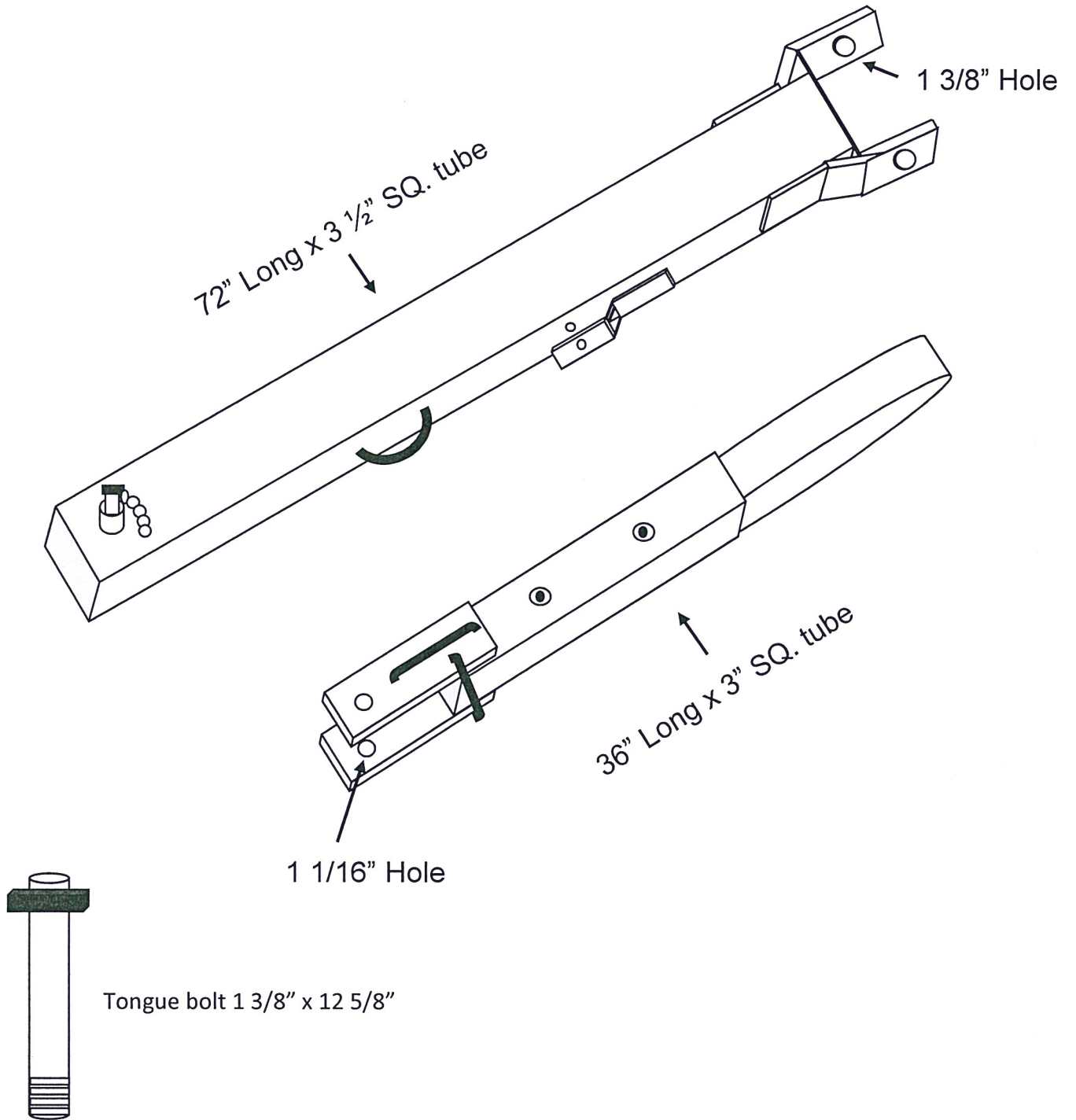

14 Ton wagon (front) w/ RB

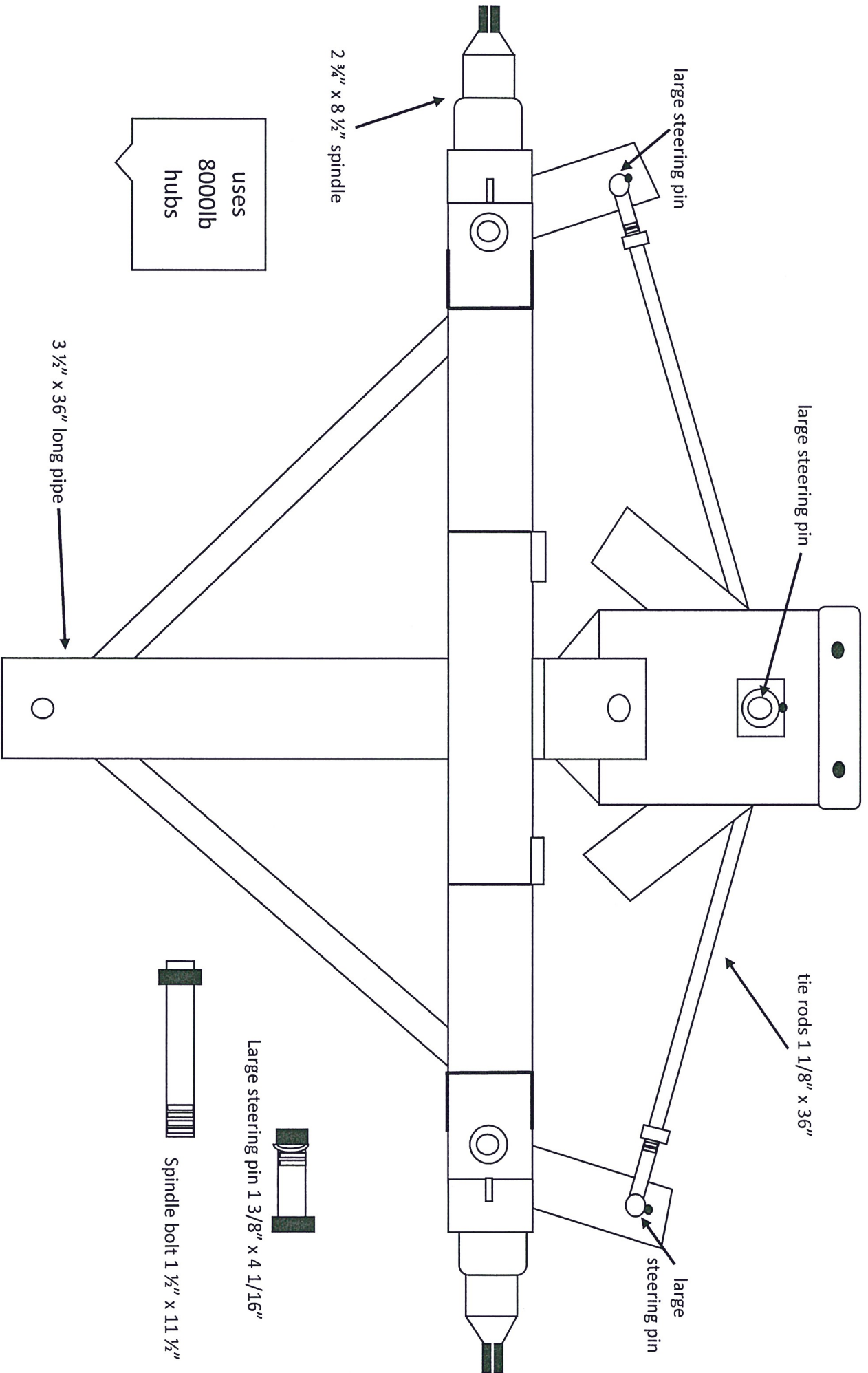

15 Ton Wagon (front) w/ RB

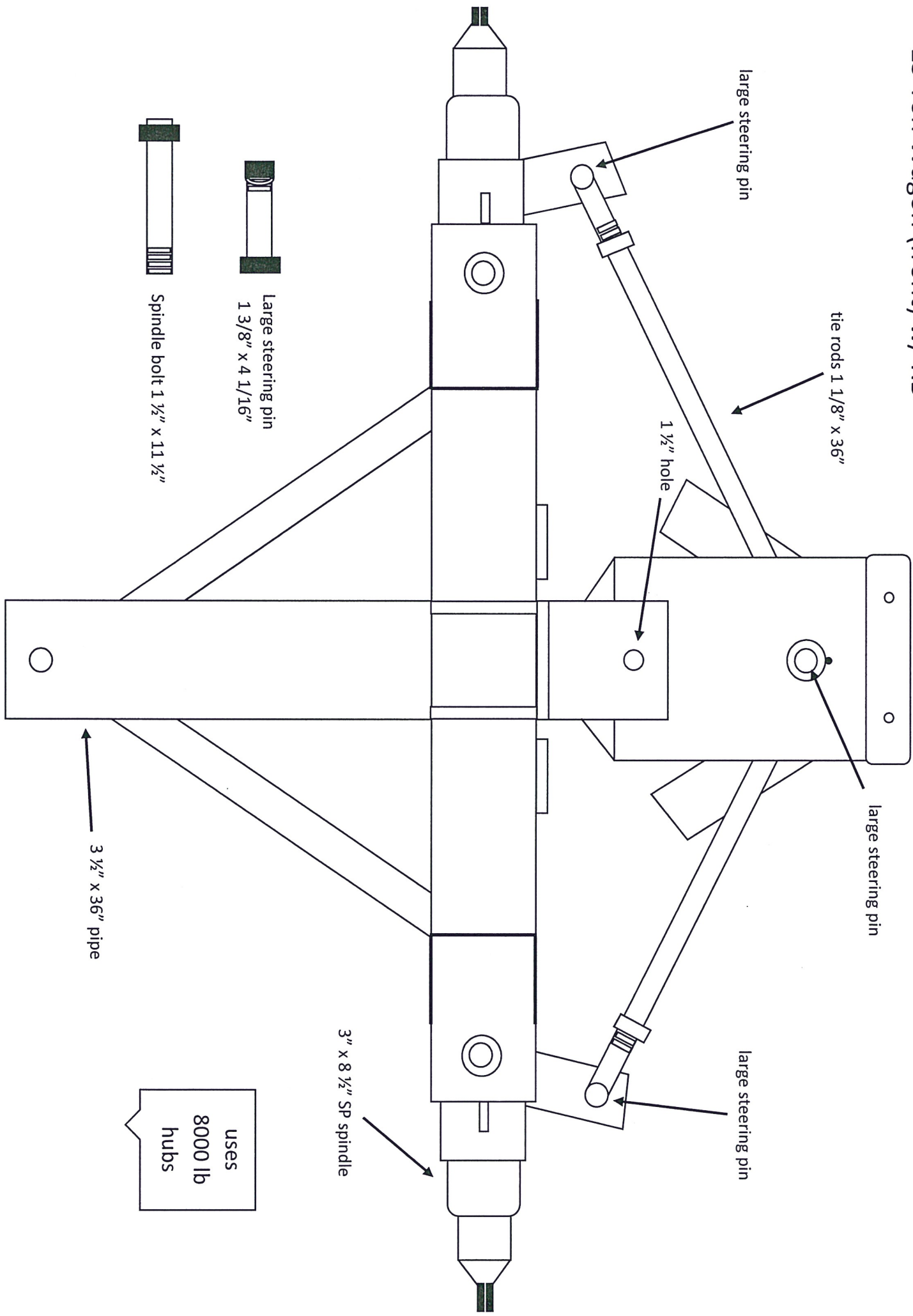

14/15 Ton Short Tongue (Hitch)

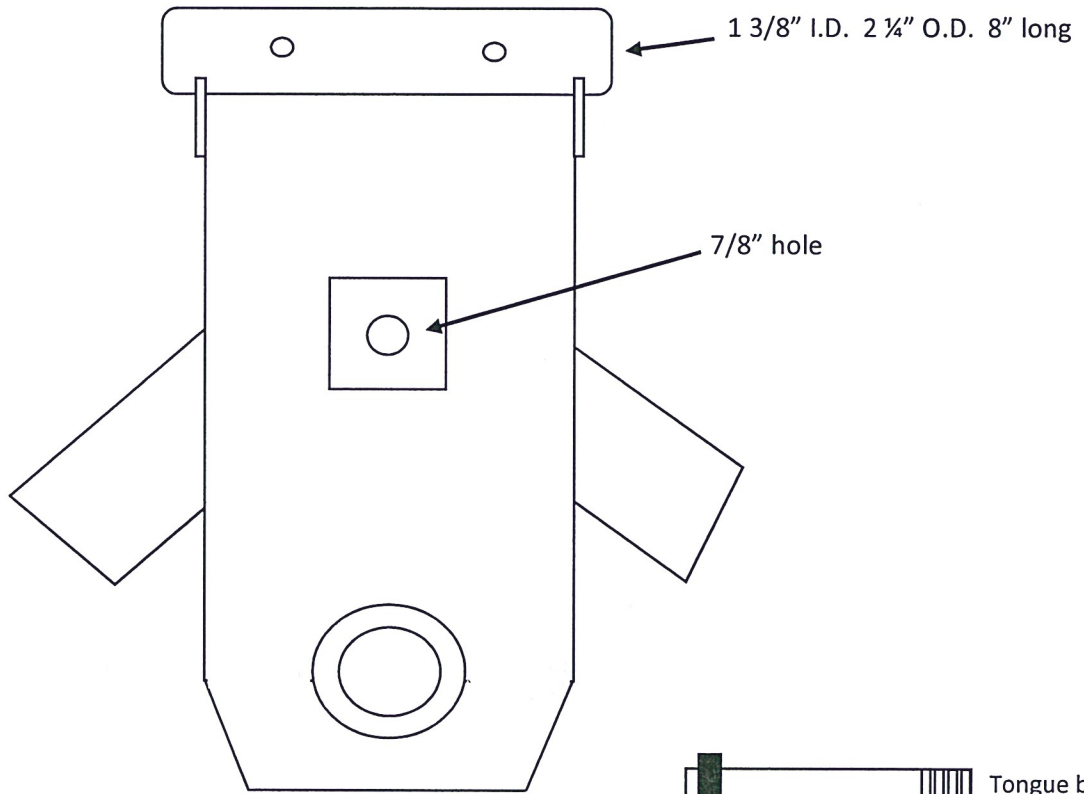

Tongue bolt 1 3/8" x 12 5/8"

The image shows a horizontal bolt with a hexagonal head on the left and a threaded section on the right. The head is shaded dark grey.



Short Tongue bolt 1 1/2" x 9 7/8"

The image shows a horizontal bolt with a hexagonal head on the left and a threaded section on the right. The head is shaded dark grey.

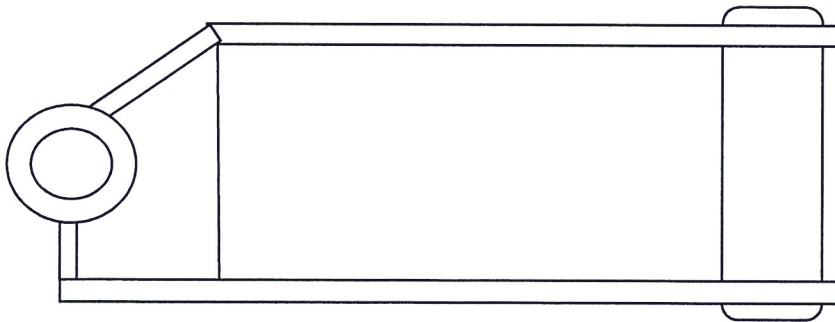

24 ton (front) w/ RB

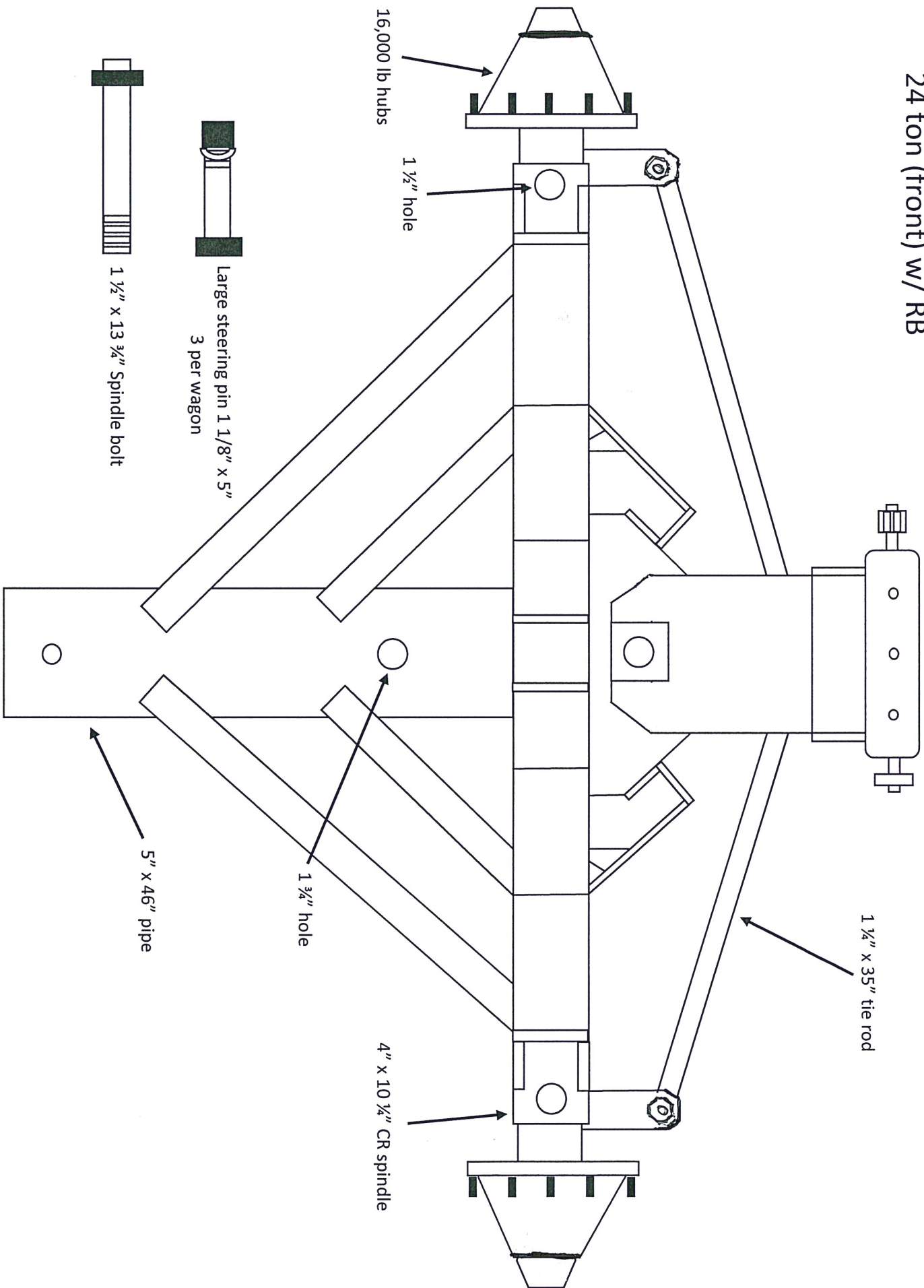

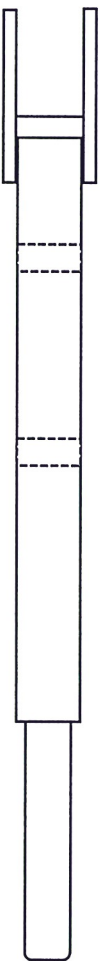
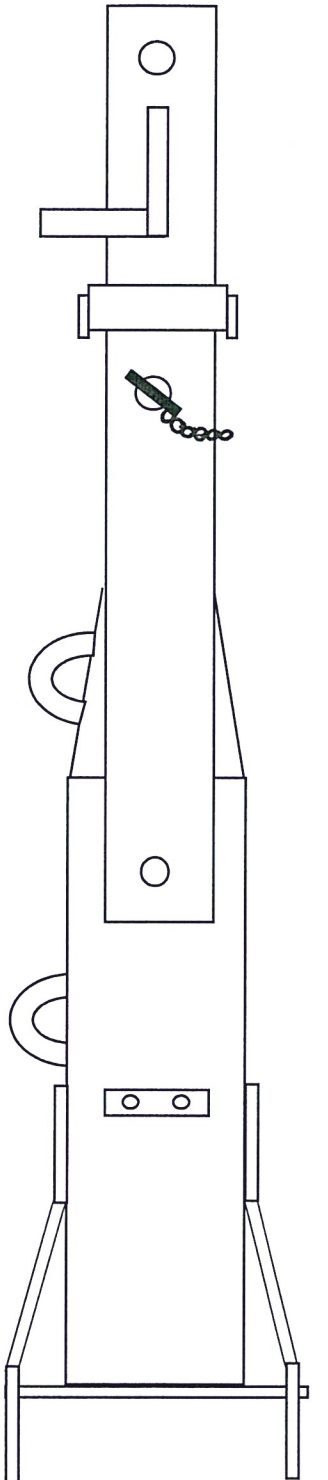

24 TON tongue and bolts

FRONT SPINDLE ASSEMBLY (LEFT SIDE) 14 TON MARKET WAGON

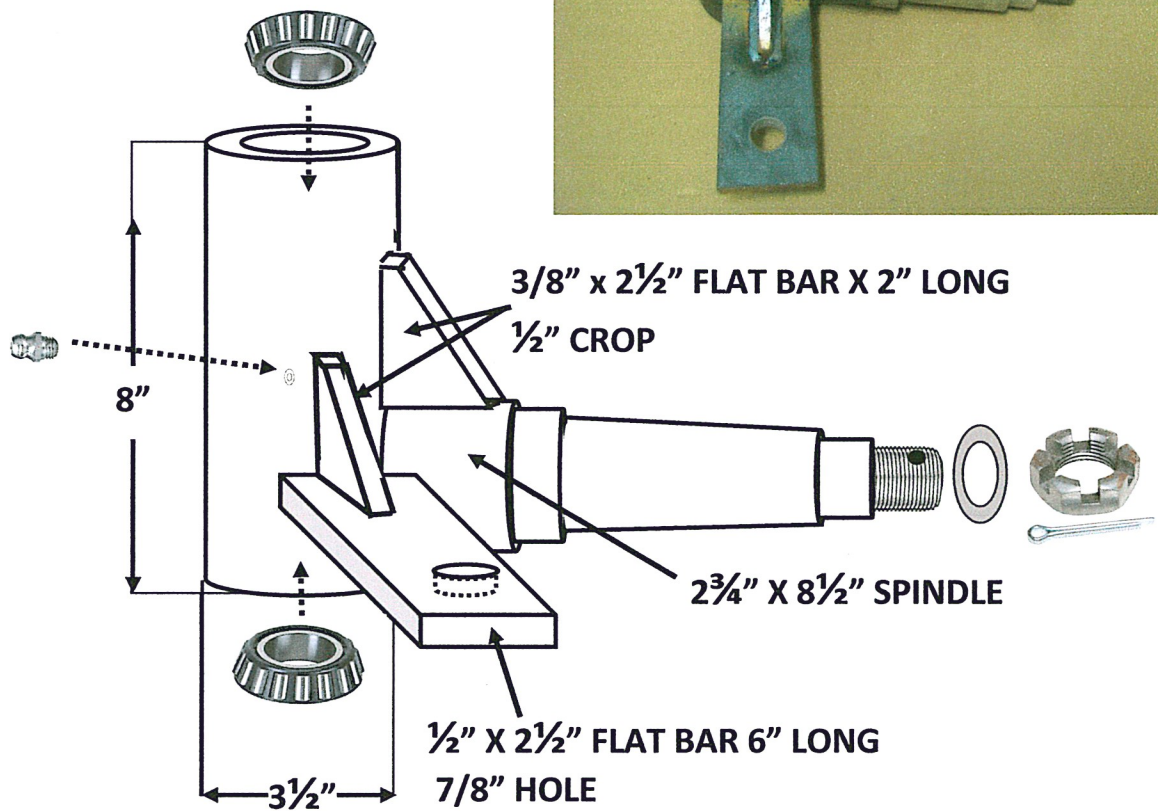

GREASE FITTING IS ON
THE OPPOSITE SIDE OF
THE SPINDLE TUBE FROM
THE FLAT BAR

FRONT SPINDLE ASSEMBLY (LEFT SIDE) FOR 10/11 TON MARKET WAGON

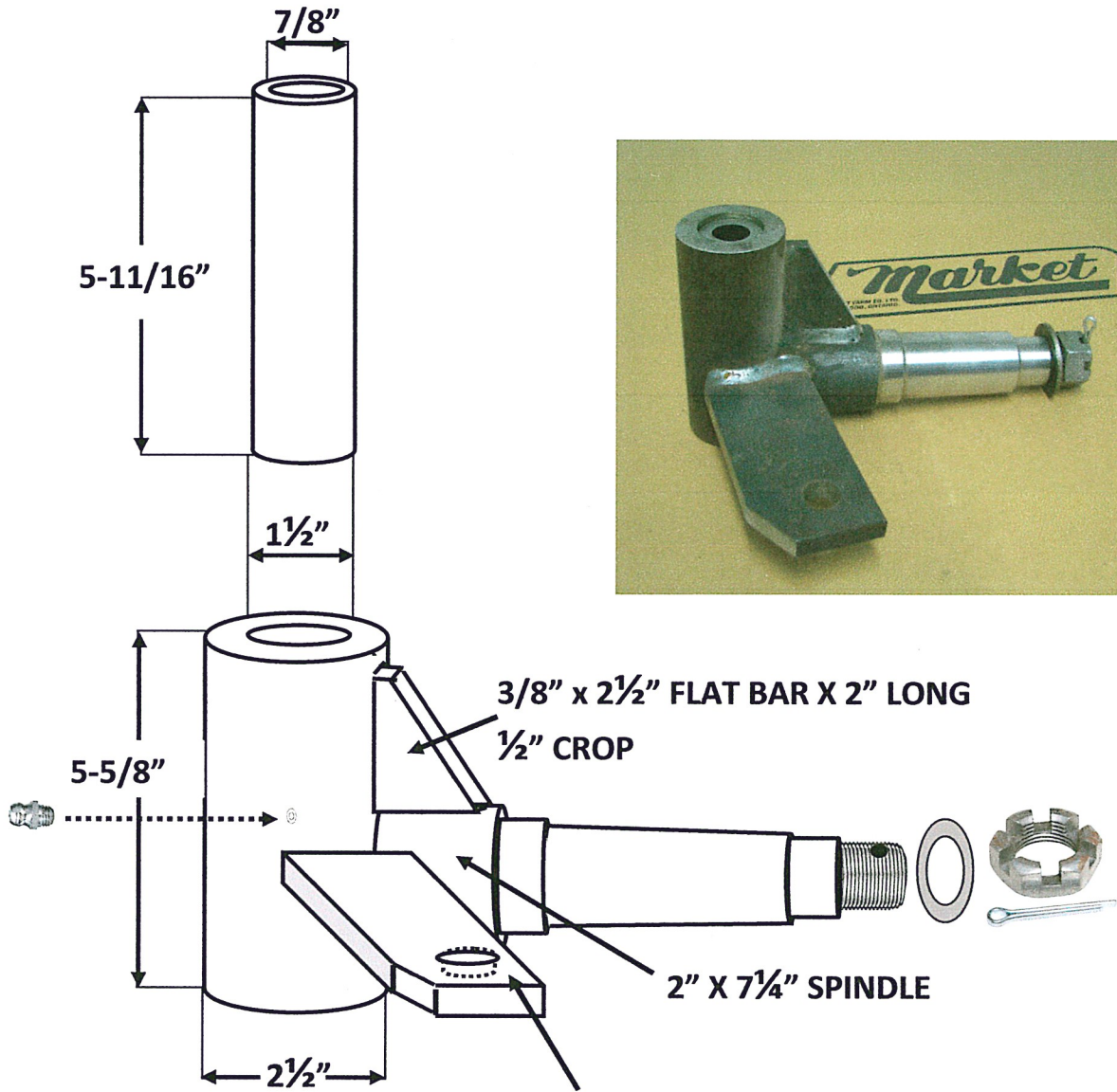

GREASE FITTING IS ON
THE OPPOSITE SIDE OF
THE SPINDLE TUBE FROM
THE FLAT BAR

FRONT SPINDLE ASSEMBLY (LEFT SIDE) FOR 10 TON ELMIRA WAGON

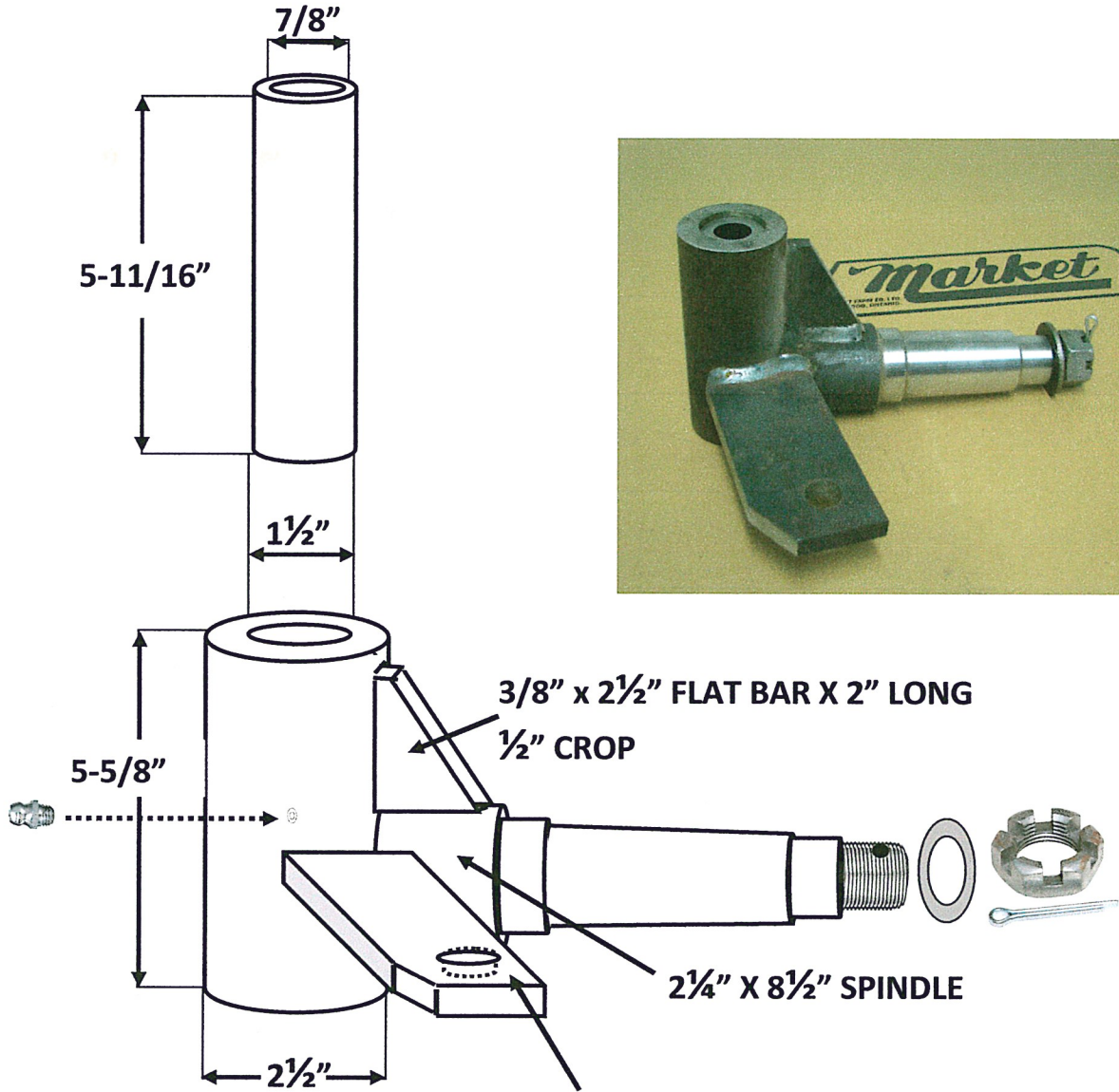

GREASE FITTING IS ON
THE OPPOSITE SIDE OF
THE SPINDLE TUBE FROM
THE FLAT BAR



FRONT SPINDLE ASSEMBLY (LEFT SIDE) 12 TON MARKET/ELMIRA WAGON

