



**OPERATOR'S MANUAL
SET-UP INSTRUCTIONS
&
PARTS LIST**

SWIVEL STYLE PLASTIC GRAVITY BOX AUGER



MARKET FARM EQUIPMENT LIMITED, R.R.#1 DASHWOOD, ONTARIO, CANADA

TEL# 519-238-2301 FAX# 519-238-6044 E-MAIL: mfeltd@execulink.com

www.marketfarmequipment.com

“SERVING THE FARM INDUSTRY SINCE 1962”

WARRANTY PROCEDURE

MARKET FARM EQUIPMENT WARRANTS THEIR MANUFACTURED PRODUCTS TO BE FREE FROM DEFECTS IN MATERIAL AND WORKMANSHIP FOR A PERIOD OF ONE (1) YEAR AFTER THE DATE OF PURCHASE TO THE FIRST END USER AND IS SUBJECT TO THE FOLLOWING CONDITIONS.

- 1. Damage caused by improper use, negligence, or operation beyond rated capacity, improper set-up, adjustment, or any unauthorized modifications made by the dealer or customer, shall void this warranty.**
- 2. Notification of damage or warranty claims must be submitted to Market Farm Equipment (M.F.E.) within seven (7) days of the date of failure.**
- 3. All defective parts must be made available by the dealer, for inspection by M.F.E. if required, and returned at the dealer's expense.**
- 4. All warranty claims must be approved by M.F.E.**
- 5. The labour and freight required to replace defective parts is not reimbursable.**
- 6. Exchange, credit or warranty status will be based on the results of the inspection of damaged items by the manufacturer.**
- 7. Credit will be issued if and when the warranty claim is approved and MUST NOT be deducted from the account by the dealer.**
- 8. Products and/or parts not manufactured by M.F.E. are subject to their own manufacturer's warranty conditions.**

WARRANTY CONSIDERATION IS ONLY VALID WHEN THE WARRANTY REGISTRATION FORM HAS BEEN RECEIVED BY MARKET FARM EQUIPMENT.

WARRANTY REGISTRATION

MARKET FARM EQUIPMENT LIMITED
71796A BLUEWATER HIGHWAY, ONTARIO, CANADA, N0M 1N0
Fax: 519-238-6044 E-mail: mfeldt@execulink.com

Purchaser's warranty protection on this equipment is valid only when this registration form is completed by the purchaser and returned to Market Farm Equipment Limited.

Date of purchase: _____

Type of equipment: _____

Model number: _____ Serial number: _____

PURCHASER'S SIGNATURE INDICATES:

- Acceptance of equipment, fully assembled () unassembled ()
- Receipt of operator's manual
- Clear understanding of warranty
- Receipt of instructions on special safety equipment available
- Receipt of instructions on safe and proper operating procedures

PURCHASER:

Name: _____

Signature: _____

Mailing Address: _____

Prov./State: _____ Postal/Zip Code: _____

Telephone number: _____

Purchased from: _____

THIS WARRANTY MUST BE VALIDATED BY THE MANUFACTURER

It is valid only when a copy of the registration has been received by the manufacturer at address shown.

MARKET FARM EQUIPMENT LIMITED
EXPRESS WARRANTY

Market Farm Equipment Limited warrants against defects in construction and materials for a period of ONE year. We reserve the right to inspect and decide whether material or construction was faulty, or whether abuse or accident voids our guarantee.

This warranty does not cover a component which fails, malfunctions or is damaged as a result of (I) improper modification or repair, (II) accident, abuse or improper use, including loading beyond the specified maximum weights and requirements (III) improper or insufficient maintenance, or (IV) normal wear and tear.

THIS WARRANTY IS EXPRESSLY IN LIEU OF ALL OTHER WARRANTIES OR CONDITIONS, EXPRESS, IMPLIED OR STATUTORY, INCLUDING ANY IMPLIED WARRANTY OF MERCHANTABILITY OR FITNESS FOR A PARTICULAR PURPOSE.

In no way shall Market Farm Equipment Limited be liable for special, direct, incidental or consequential damages of any kind, including but not limited to labour charges.

The exclusive remedy under this warranty shall be repair or replacement of the defective component at Market Farm Equipment Limited's option. This is the entire agreement between Market Farm Equipment Limited and the owner about warranty. NO M.F.E. Ltd. employee or dealer is authorized to make additional warranty on behalf of Market Farm Equipment Limited.

(Fill in the following for future reference)

Serial number: _____

Date of purchase: _____

Purchased from: _____

SAFETY INFORMATION

- Before using auger READ and UNDERSTAND SAFETY INSTRUCTIONS.
- After hydraulic lines are connected, run auger empty to ensure the flighting is rotating in the proper direction. (if ran backwards, damage may occur)
- Auger should be empty when moving or transporting.
- Hydraulic oil leaking under pressure can cause injury. Make sure all hydraulic connections are tight. Before disconnecting hydraulic lines, relieve pressure.
- Do not adjust, clean or service auger while it is running.
- Keep all safety shields in place. Replace any safety decals that become lost or damaged.
- Do not operate the auger in a manner that it was not intended for.
- When transporting, always keep auger in its lowest position.

HYDRAULIC SYSTEM OPERATING RESTRICTIONS

MAXIMUM FLOW – 20 G.P.M. MAXIMUM PRESSURE – 2500 P.S.I.

MAXIMUM FLOW AND MAXIMUM PRESSURE conditions MUST NOT occur simultaneously. Damage will occur and warranty will be void. Use only ½" hydraulic hose when plumbing. Smaller hose will create heat that will burn out the hydraulic motor and warranty will be void.

Do not tee into hydraulic lift cylinders on planters or drills.

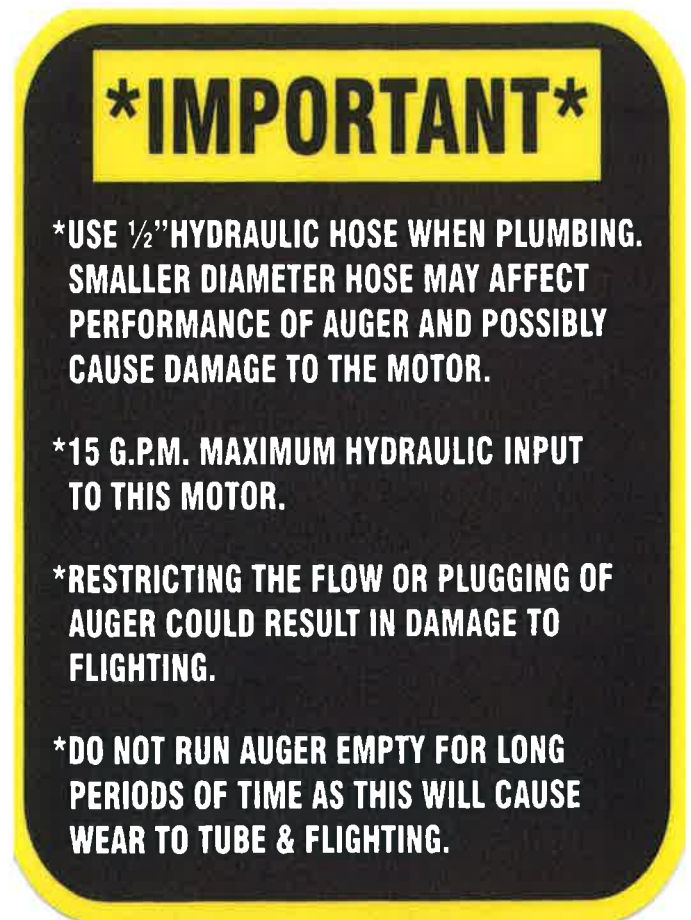

SET-UP INSTRUCTIONS FOR SWIVEL STYLE AUGER

- 1: Remove grain chute from gravity box. Measure width between angle iron door supports. Deduct $\frac{3}{4}$ " from measurement and cut pipe on hopper (#12) to fit making sure to keep center of pipe in line with the center of the hopper.**
- 2: Slide hopper mounting brackets (#18L & 18R) into pipe on hopper. Measure again to make sure hopper will fit between the angle iron door supports. Place hopper assembly in position so that the rear, top edge of the hopper fits tight to the underside of the door lip and secure with clamps. Using the existing holes in the angle iron door supports, drill a $\frac{3}{8}$ " in mounting brackets. Remove hopper from gravity box and attach to auger using the picture frame set (#1). The swivel hopper fits most slanted or straight door side gravity boxes with a door opening up to $38 \frac{1}{2}$ " wide.**
- 3: Locate position for support cable (#3) on top lip of gravity box (Bottom lip of extensions). From the center, measure 15"-16" in both directions. Drill $\frac{3}{8}$ " holes through top lip of the gravity box. Attach the support cable using (#16) support cable spacer assemblies.**
- 4: Mount winch onto auger making sure that the handle is away for the gravity box. The winch mount clamp band may have to be reversed depending on the direction of auger storage.**
- 5: Mount auger and hopper assembly to gravity box using pre-drilled holes. It will be necessary to support upper end of auger while attaching winch cable (#6) and safety cable (#8). Mount pulley (#7) with quick link (#39) to the pulley mount clamp band (#24). Run winch cable through pulley and down to the winch. Attach cable to the winch using cable keeper. Hold cable securely while tighten onto the spool. The augers weight should engage the brake on the winch, holding it in place. Attach looped end of safety cable to the center of the top lip of gravity box with both a $\frac{1}{2}$ " & $\frac{3}{8}$ " flat washer. Secure with $\frac{3}{16}$ " cable clamp (#28).**
- 6: Attach $\frac{1}{2}$ " hydraulic hoses to motor (make sure to use Teflon tape). Secure hoses to auger using hydraulic line holders (#17). Do not over tighten. Secure hoses to front leg of gravity box with line holder (#17). You will have to drill a $\frac{3}{8}$ " hole if one is not available.**
- 7: Swing auger into transport position. Using the transport bracket (#10) as a template, drill and mount transport bracket and backer plate (#11). Proper position of transport bracket is straight up and parallel to the vertical corner of the gravity box. The cradle can be rotated to align with the auger. Tighten bolt on cradle. Attach rubber tarp strap (#9) to hole**

60" SWIVEL HOPPER



Follow steps #1 & #2 to mount the hopper.

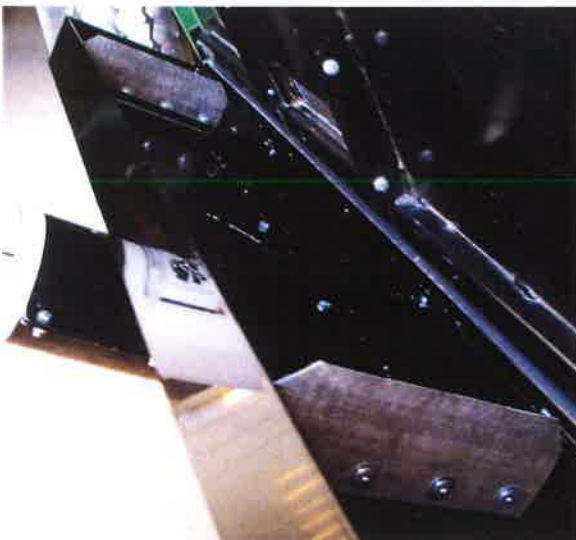

The deflectors can be mounted to best suit your gravity box door width.

They can also be mounted on the outside of the angle iron that holds the door in position.

in transport bracket brace. Crimp s-hook. Secure auger in cradle with the rubber straps other s-hook and eyebolt.

8: Install valve handle (#23) and control rope (#13).

9: Install flexible downspout (#14) using the hose clamp (#27B). An optional telescoping downspout may be used.



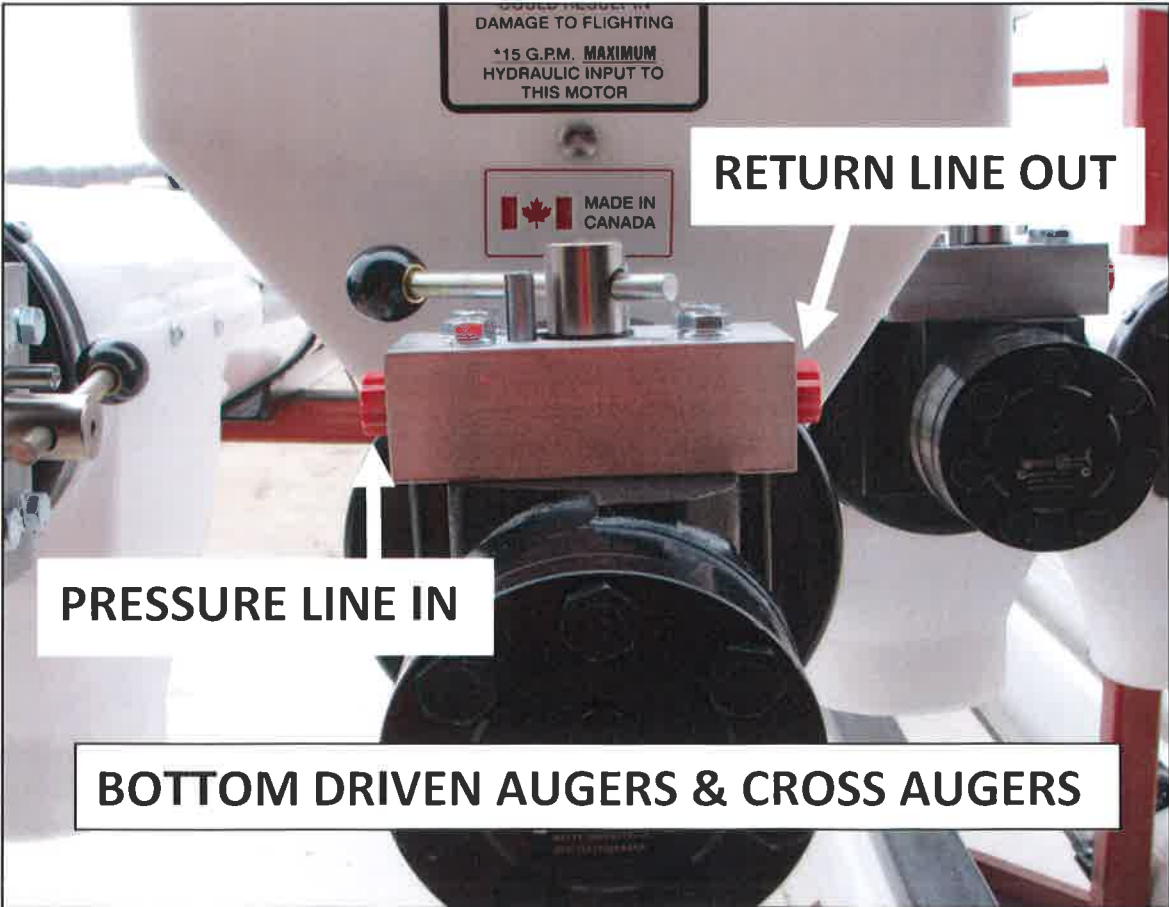
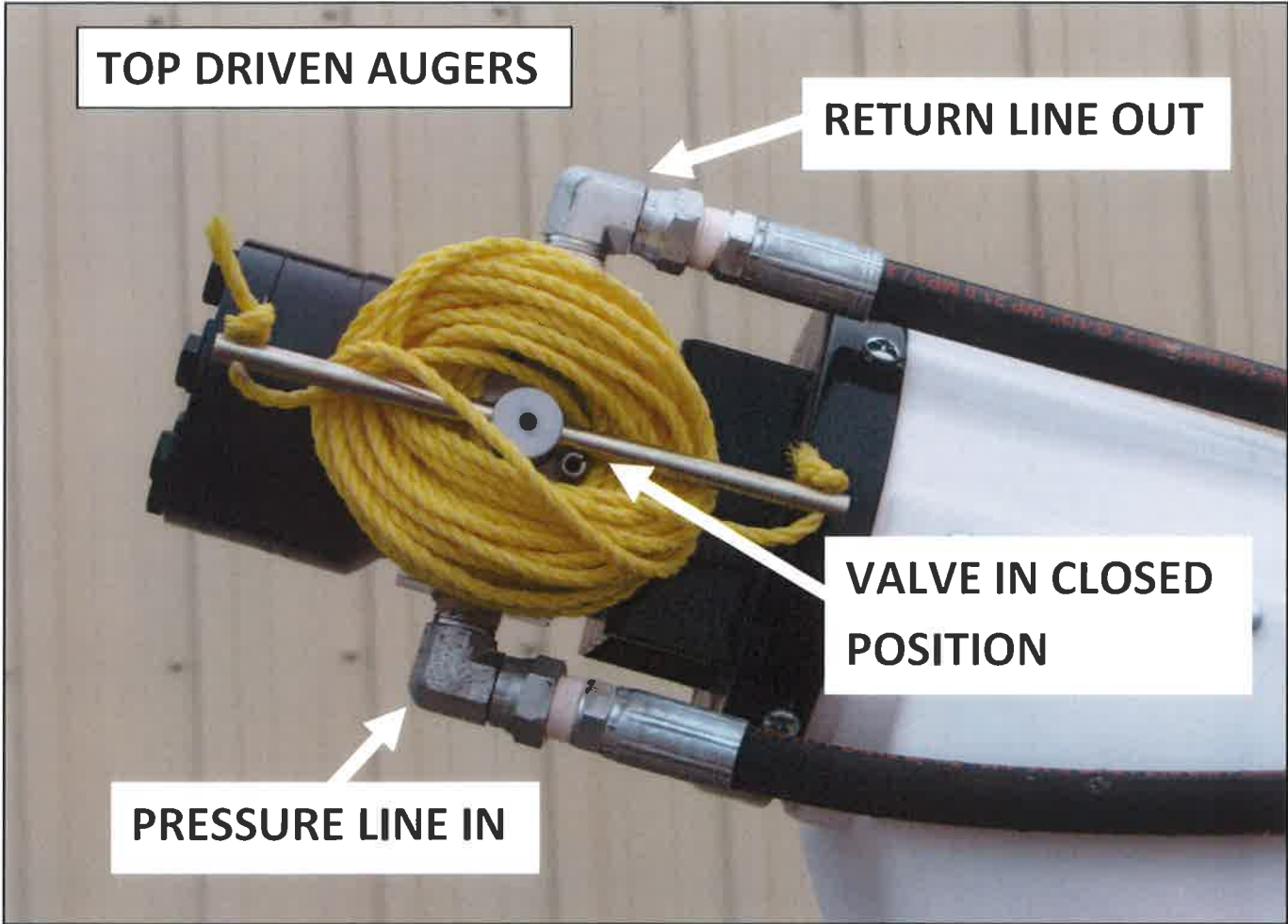

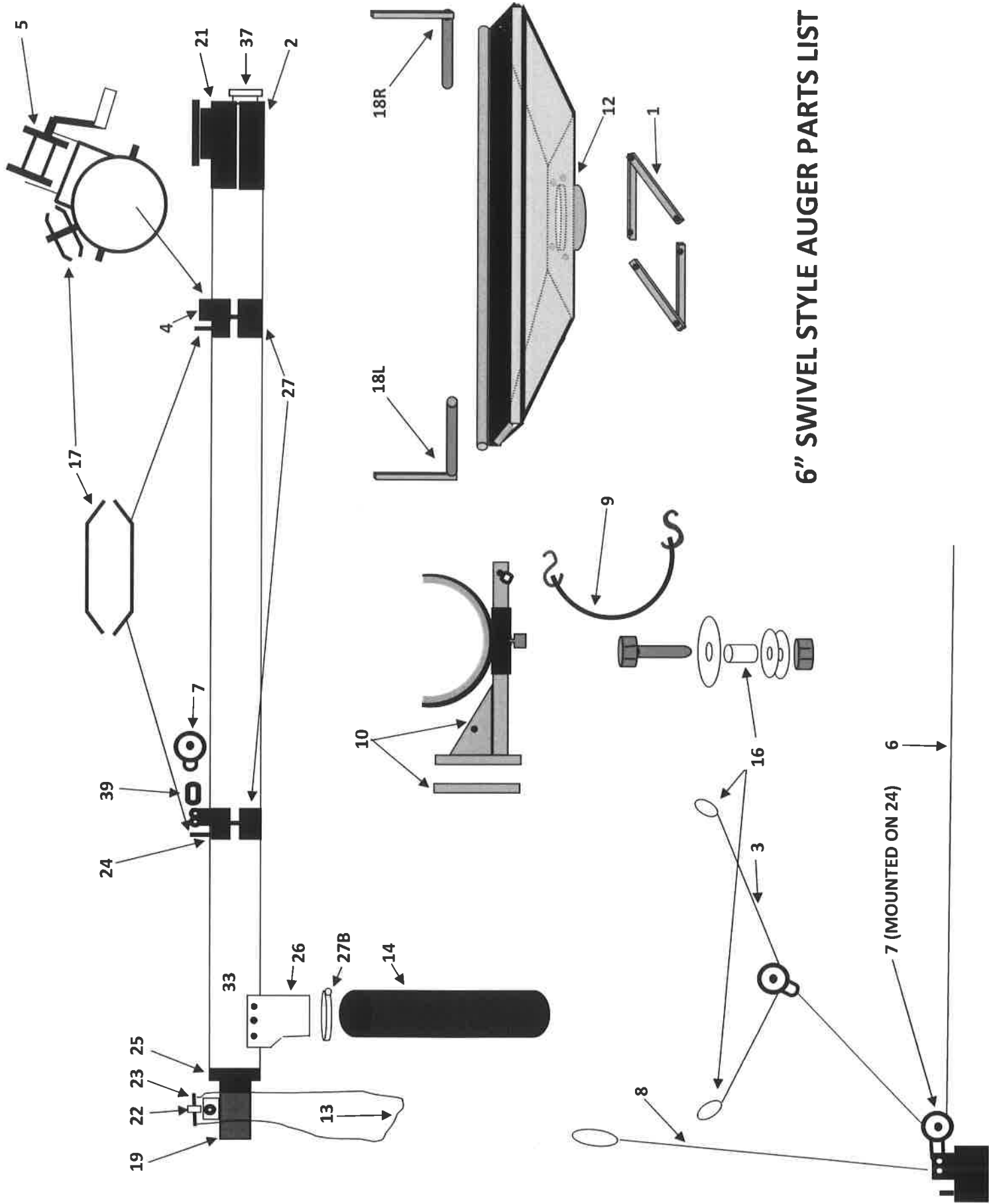

6" SWIVEL STYLE AUGER PARTS LIST

6
 7 (MOUNTED ON 24)
 8

8" TRANSPORT BRACKET

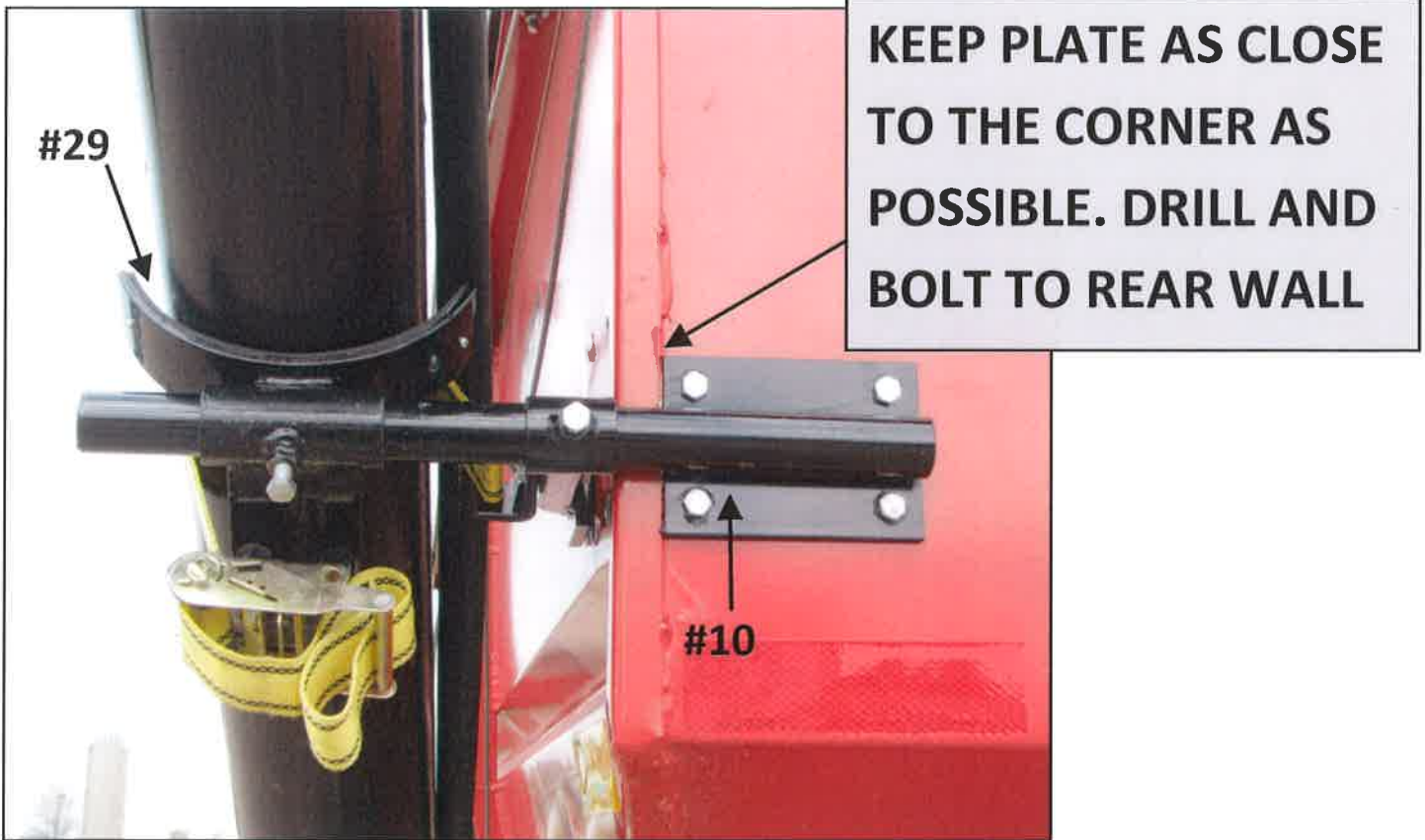

SLIDE BRACE OVER UNTIL IT SITS FLUSH ON THE GRAVITY BOX WALL. DRILL AND BOLT TO WALL

8" SWIVEL STYLE AUGER PARTS LIST

REF# DESCRIPTION

1	PICTURES FRAME (2 PC. SET) (699)
3	SUPPORT CABLE (1169)
4	½ CLAMP BAND (WINCH MOUNT) (#4, #27 & (2) OF #17 FOR A COMPLETE ASS.) (113)
5	BRAKE WINCH (459)
6	14' WINCH CABLE C/W PULLEY (1560)
7	PULLEY (376)
8	8' SAFETY CABLE (1561)
10	TRANSPORT BRACKET (GRAVITY BOX STYLE) (#10, #10A, #11 & #29 FOR A COMPLETE ASSEMBLY) (945)
10A	RATCHET C/W STRAP
12	SWIVEL HOPPER (495)
13	12' CONTROL ROPE (102)
14	4' DOWNSPOUT (685) STANDARD LENGTH IS 4' (OPTIONAL TELESCOPIC DOWNSPOUT NOT SHOWN)
16	SUPPORT CABLE SPACERS (1574)
17	HYDRAULIC LINE HOLDERS (532)
18L	LEFT HOPPER MOUNTING BRACKET
18R	RIGHT HOPPER MOUNTING BRACKET
	> SET (1369)
19	6 CU. INCH (MANIFOLD) HYDRAULIC MOTOR (395)
20	MKT-264 HYDRAULIC HOSE ASSEMBLY 1/2" x 22' LONG (1076)
21	SWIVEL INLET ASSEMBLY (745)
22	MANIFOLD MOUNT VALVE ½" NPT (117)
23	VALVE HANDLE (580)
24	½ CLAMP BAND (PULLEY MOUNT) (#24, #27 & #17 FOR A COMPLETE ASS.) (1058)
25	MOTOR MOUNTING PLATE (1014)
26	AUGER DISCHARGE SPOUT (928)
27	½ CLAMP BAND (522)
27B	8" HOSE CLAMP (779)
28	1/4" CABLE CLAMP FOR SAFETY CABLE (NOT SHOWN) (108B)
29	RUBBER PROTECTIVE STRIP (414B)
33	RAW PLASTIC TUBE (SPECIFY 12', 14' OR 15' & AUGER STYLE) (528)
37	CLEANOUT C/W THREADED END CAP (1126)
378	THREADED END CAP ONLY (898B)
39	5/16" QUICK LINK (587B)
	ALL NUTS & BOLTS SOLD SEPARATELY

FLIGHTING STYLES: STRAIGHT BLADE PLASTIC, 7" CUPPED PLASTIC, & CUPPED STEEL (SPECIFY LENGTH & AUGER STYLE)

OPTIONAL VALVES FOR HYDRAULIC AUGERS

Note: These optional valves do not replace the shut-off valve on the auger.

A directional valve fitting can be installed to restrict the auger from running in the reverse direction. This valve should be installed on the return line, between the valve on motor and the tractor. Thread is ½" NPT. **RECOMMENDED FOR AUGERS THAT SHOULD NOT BE RUN IN REVERSE, AS IT MAY CAUSE DAMAGE TO THE FLIGHTING.**

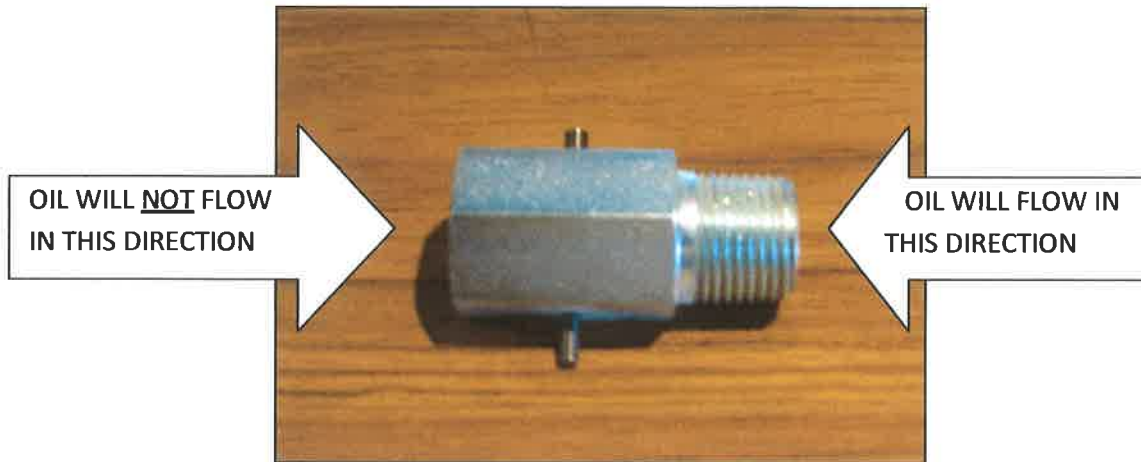

An in-line, pressure compensated, nonadjustable flow regulator valve is available for CLOSED CENTER HYDRAULIC SYSTEMS. In the controlled direction, this regulator will maintain a constant flow rate of 10 GPM. This valve should be installed on the pressure line, between the tractor and the valve on motor. Thread is ¾" NPTF (must be reduced to ½")

RECOMMENDED FOR AUGERS OPERATED BY LARGER TRACTORS WITH LARGER HYDRAULIC OUTPUT.

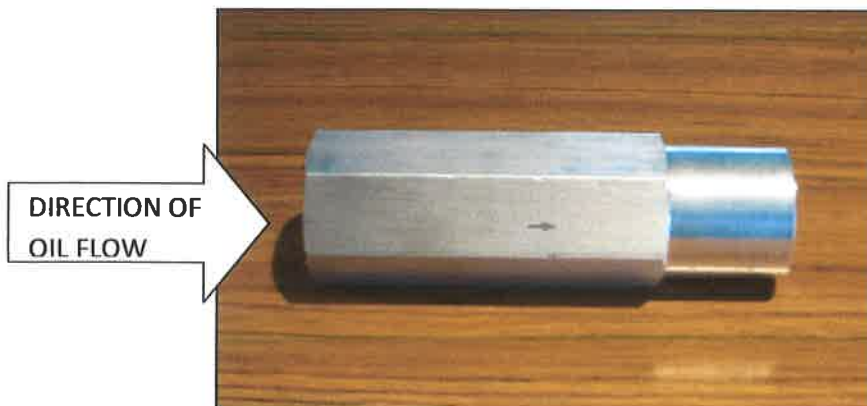

Augers operate best at 10-12 GPM & 1200-1500 PSI.

**Market Farm Equipment Ltd. RR# 1 Dashwood, Ontario, Canada N0M 1N0
E-Mail mfeltd@execulink.com Web-Site www.marketfarmequipment.com**

IMPORTANT OPERATING INSTRUCTIONS

- 1: NEVER LEAVE THE DOWNSPOUT (TELESCOPING OR FLEX) UNATTENDED WHILE THE AUGER IS RUNNING. IF IT IS NECESSARY TO LEAVE THE DOWNSPOUT, SHUT AUGER OFF.**
 - 2: NEVER HOLD THE DOWNSPOUT (TELESCOPING OR FLEX) DOWN TOO LOW. THE MATERIAL CAN BUILD UP AND PLUG THE DISCHARGE. PLUGGING AND DAMAGE TO FLIGHTING CAN OCCUR QUICKLY. TO AVOID COSTLY DOWNTIME AND REPAIR COSTS ALWAYS BE AWARE OF HOW FULL YOUR SEED/FERTILIZER HOPPERS ARE GETTING WHILE FILLING.**
 - 3: NEVER EXCEED THE MAXIMUM 15 G.P.M. HYDRAULIC INPUT. MOST AUGERS REQUIRE 9-12 GPM AT 1200-1500 PSI TO RUN PROPERLY.**
 - 4: NEVER RUN AUGER EMPTY FOR LONG PERIODS OF TIME AS THIS WILL CAUSE WEAR TO THE TUBE & FLIGHTING.**
 - 5: OPTIONAL FLOW REGULATOR VALVES (10 GPM MAX.) AND DIRECTIONAL VALVES ARE AVAILABLE.**
 - 6: OPTIONAL ELECTRIC SOLENOID VALVES ARE AVAILABLE WITH CABLE OR REMOTE SHUT-OFF/ON FEATURES.**
- PLEASE READ ALL SAFETY/IMPORTANT DECALS ON THE AUGER. UNDERSTANDING THE AUGERS REQUIREMENTS AND PROPER USE WILL ENSURE A LONG AND TROUBLE FREE LIFE FOR THE AUGER.**

IMPORTANT

YOUR AUGERS DOWNSPOUT SHOULD NEVER BE SET DOWN OR LEFT UNATTENDED WHILE THE AUGER IS RUNNING.

MATERIAL CAN BUILD UP QUICKLY CAUSING THE DOWNSPOUT AND AUGER TO PLUG. THIS CAN DAMAGE THE AUGERS FLIGHTING AND MOTOR.

ALWAYS TURN AUGER OFF BEFORE LEAVING THE DOWNSPOUT TO ATTEND TO OTHER MATTERS.

